

 **LLOYTRON[®]**

OPERATING INSTRUCTIONS

800w Centrifugal Juice Extractor



MODEL: E5203WH

thank you

Thank you for the purchase of this quality **LLOYTRON** product. Used carefully and in accordance with the instructions enclosed, it should give you trouble free service over a long period of time. Please keep these instructions for future reference.

FEATURES

- 800w Power Consumption
- 500ml Capacity Juice Jug
- 1.3 Litre Capacity Pulp Container
- Clear Lid for easy viewing
- Stainless Steel Centrifugal Sieve
- 2 Speed Operation with Pulse Control
- 76mm Diameter Feeding Tube & Food Plunger
- Safety Cut Out Switch



SPECIFICATIONS

Operating Voltage: 220-240v~ 50/60Hz
Wattage: 800w



IMPORTANT SAFEGUARDS AND PRECAUTIONS

SAVE THESE INSTRUCTIONS

- Read all instructions carefully
- For Household Use only. Not intended for commercial use.
- Only for use indoors.
- Do not use outside or in damp conditions.
- Before plugging into mains socket, check whether supply line voltage and current rating are in compliance with the rated electrical parameters shown on the rating label.
- Keep away from hot surfaces, such as gas or electric hobs and ovens etc
- Do not use for any purposes other than the appliances intended use.
- This appliance is not intended to be operated by means of an external timer or separate remote control system.
- To prevent damage to the mains cord, do not let it pass over sharp corners, edges or hot surfaces.
- If the supply cord is damaged, do not use. Check before each use!
- If the supply cord is damaged, it must be replaced by a special cord or assembly available from the manufacturer or its service agent.
- Do not use if any part of this appliance is damaged in any way.
- Always unplug when not in use.
- To prevent against the risk of electric shock, do not submerge any part of this appliance in water, unless advised in this manual.
- This appliance should only be used on a flat surface.

- This appliance can be used by children aged from 8 years and above and persons with reduced physical, sensory or mental capabilities or lack of experience and knowledge if they have been given supervision or instruction concerning use of the appliance in a safe way and understand the hazards involved.
- Children shall not play with this appliance.
- Cleaning and user maintenance shall not be made by children without supervision.

- Always disconnect the appliance from the supply if it is left unattended and before assembling, disassembling or cleaning.
- Blades are very sharp, even when not in use. Caution should be taken when cleaning or handling blades.
- Ensure correct assembly of all parts before use.
- Blades should be checked regularly for any damage or cracks.
- Do not use when empty or below the minimum mark.
- Do not operate in the presence of flammable fumes or mix flammable materials.
- Do not allow children to use this appliance without supervision.

LOCATION OF CONTROLS

1. Food Plunger
2. Juice Cover
3. Filter Sieve
4. Juice collector
5. Safety Catches
6. Motor Unit
7. Pulp container
8. Juice Container
9. Control Dial

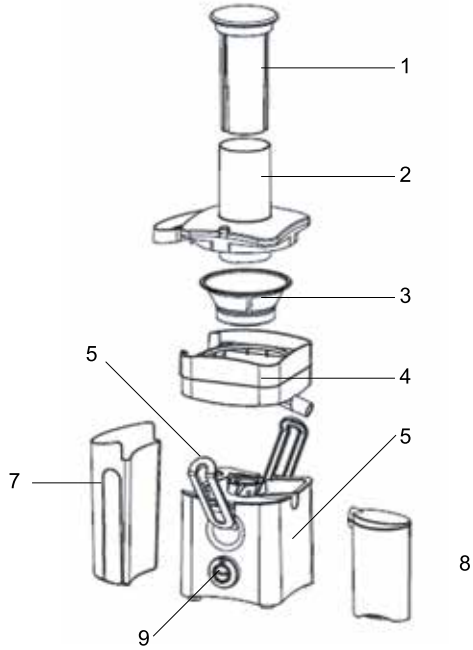

OPERATION

FOOD PREPARATION

- Remove stones (plums, peaches, cherries etc).
- Remove tough skins (melons, pineapples, cucumbers, potatoes etc).
- Soft-skinned and other foods just need washing (apples, pears, carrots, radishes, lettuce, cabbage, parsley, spinach, grapes, strawberries, celery etc).

ASSEMBLY AND USE

1. Fit the Juice Collector as in Fig. A
2. Fit the Filter Sieve and push down until it into place, Fig.B.
Ensure the Filter Sieve is fitted securely inside the Juice Collector.
3. Place the Juicer Cover over the Juice Collector, Fig.C.
4. Place the tops of the Clamps on the respective slots on the Juicer Cover, leaving the Clamp Hinges resting out. Press the bottom of the Clamps in, until they snap snugly into place, Fig.D.
5. Slide the Food Pusher down the Feed Chute by aligning the groove in the Food Pusher with the small protrusion on the inside of the top of the Feeding Tube.
6. Place the Pulp Container into position by tilting slightly.
7. Place the juice jug provided under the Juice outlet .



Fig. A



Fig. B



Fig. C



Fig. D

8. Cut the food into small pieces to fit the feed tube. De-Core any Apples before placing in chute.
9. Switch on and push down with the pusher. Use speed 1 (low speed) for softer food; speed 2 (high speed) for harder food.
 - Some very hard foods may make your juicer slow down or stop. If this happens switch off and unblock the filter.
 - Switch off and clear the pulp collector regularly during use.

NOTE: Always unplug after use

DIS-ASSEMBLE

Reverse procedure for Assembly.

HINTS

- Insert soft food slowly to get the most juice.
- Vitamins disappear - the sooner you drink your juice, the more vitamins you'll get.
- If you need to store the juice for a few hours put it in the fridge. It will keep better if you add a few drops of lemon juice.
- Don't drink more than three 230mls (8 fl.oz.) glasses of juice a day unless you're used to it.
- Dilute juice for children with an equal amount of water.
- Juice from dark green (broccoli, spinach etc) or dark red (beetroot, red cabbage etc) vegetables is extremely strong, so always dilute it.
- Fruit juice is high in Fructose (fruit sugar), so people with diabetes or low blood sugar should avoid drinking too much.
- Don't mix fruit and vegetable juice together (apart from apple and carrot), it can cause painful bloating.

CLEANING AND CARE

MAINTENANCE:

This appliance has been designed to operate over a long period of time with a minimum of maintenance. Continuous satisfactory operation depends upon proper care and regular cleaning.

Warning! Before performing any maintenance or cleaning of this appliance, disconnect the appliance from the electrical supply.

CLEANING:

Never put the Motor Unit under a tap or in a dishwasher, but clean it with a damp sponge, and dry thoroughly. Some foods may discolour plastic parts, eg Carrots. Rubbing with a cloth dipped into vegetable oil helps to remove these stains.

The Containers, Plunger, Juice Cover and Juice Collector can all be washed in hot soapy water and dried with soft clean cloth.

The Sieve should be cleaned with a soft brush.

YOU MUST CHECK THE SIEVE REGULARLY FOR SIGNS OF DAMAGE. DO NOT USE IF DAMAGED.

THIS ITEM IS NOT DISHWASHER SAFE

WEEE/ENVIRONMENTAL PROTECTION



Disposal of Electrical and Electronic Equipment

Do not dispose of this product with household waste. For the proper treatment, recovery and recycling please take this product to the appropriate waste collection point. If you are unsure where this may be, please contact your local authority. Improper disposal may be harmful to the environment.

UK PLUG REWIRING

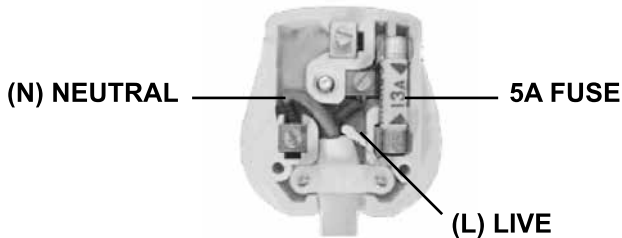

Your appliance operates on 220-240V~50Hz AC Mains and comes fitted with a 3-pin BSI Approved plug, so that it is ready for use by simply plugging into AC Mains. Should you need to change or refit a plug, proceed as follows: -

IMPORTANT:

The wires in the mains lead are coloured in accordance with the following code:

BLUE: NEUTRAL (N)
BROWN: LIVE (L)

As the colours of the wires in the mains lead of this appliance may not correspond with the coloured markings identifying the terminals in your plug, proceed as follows:

The BLUE wire must be connected to the terminal which is marked with the letter "N" or coloured BLACK.

The BROWN wire must be connected to the terminal which is marked with the letter "L" or coloured RED.

DO NOT CONNECT EITHER WIRE TO THE EARTH TERMINAL OF A 3-PIN PLUG

Always ensure that the Mains Cord is located into the Plug through the Cord Guard or Cable Clamp, and that the Cord Guard screws are tightened to clamp the Cord (outer sheath and inner coloured wires) in position in the Plug. Make sure the Plug top is also fitted securely.

The supply cord cannot be replaced. If the supply cord is damaged, the appliance should be scrapped.

This appliance must be protected by a 5 Amp fuse in a 13 Amp type (BS1363) plug. Should you need to replace the fuse, use only an ASTA approved BS1362 fuse.



LLOYTRON® CUSTOMER SERVICES

If you have any queries about this product, there are three ways to contact our customer service department:

call: 08454 81 8808

email: customerservice@lloytron.com

web: www.lloytronhelpdesk.com

To find more details on a wide range of Lloytron products please visit our website at www.lloytron.com
Lloytron plc, Laltex House, Leigh Commerce Park, Greenfold Way, Leigh, Lancashire, WN7 3XH. England, U.K